

.. EASY LIFE IN WORKSHOP ..

Glass Beading Saw with variable cutting angle (single bar) integrated with electronic Length Stop

DigiBS 4.0

-- INTEGRATED SAW SYSTEM --



DigiBS can be configured at any time to be used left or right

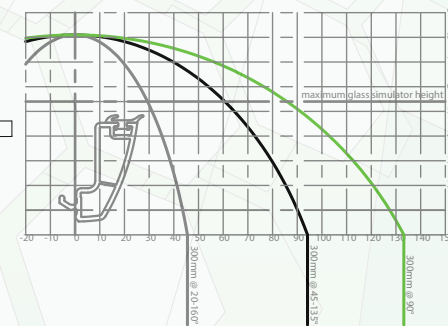
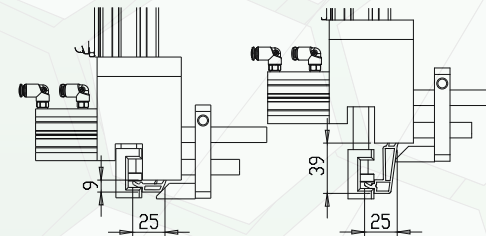
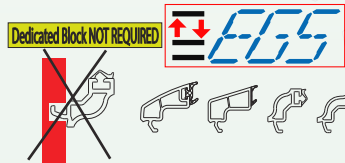

DigiBS 4.0 is a system that integrates a **Bead Saw** and an **electronic Length Stop**. The saw is an "up-cut" type (blade diameter 300mm), the positioning of the rotary table (cutting angle) is managed by the numerical control and varies between 20 ° and 160 °. The **DigiBS4.0** is specifically designed for cutting glazing beads and for this reason the DigiBS4.0 includes a quick-adjusting device for the blocks. This innovative system allows you to work a wide varied range of beads **without the additional need for profile specific bead blocks**, the design of the machine also allows you to make the 'arrow cut' (typical of PVC glazing beads) by making the two cuts required in one programmed operating sequence. The type of cut allows a very rapid cycle thanks to the reduced stroke of the blade. The electronic Length Stop is made with sturdy aluminum profiles that integrate the carriage sliding system. The positioning of the stop is managed by the numerical control and the measurement is verified thanks to a magnetic band system with an error of ± 0.1 mm. This allows you to operate with exceptional precision combined with a high positioning speed.

DigiCloud
.. EASY LIFE IN WORKSHOP .. 4.0
CLOUD SERVICE FOR OUR MACHINES



DigiIndustry 4.0
WEB BASED MACHINES SUPERVISION

- Industrial PC 15" Touch screen WINDOWS 10 IoT
- Wi-Fi and Ethernet AS STANDARD
- DigiCLOUD Service for a continuous data saving
- Remote service simple and effective.
- The on-line contextual help informs the operator about the machine controls and, in case of failures, offers a troubleshooting service guiding the operator to solve the problem with photos and electrical pneumatic diagrams directly on the screen.

DigiBS 4.0 is controlled by a 15" Touch Screen Industrial PC connected to PLC cards. The Windows 10 IoT Industrial operating system combines the simplicity of the Windows environment with the stability of systems intended for production environments. The DigiBS 4.0 control unit integrates an advanced radio interface that is able to create and manage a robust radio network in the whole workshop. All the products of the **DigiFAMILY** are able to use this network to exchange information. Integration with the **DigiBAR 4.0** electronic gauge is the most common and easiest way to work with the DigiBS4.0: a cutting list is generated in real time on the screen during the measurement cycle. The new color touch screen contains all the information the operator needs during the work cycle, the colored areas clearly and immediately indicate the status of the machine.

DigiBS 4.0 is a **CONNECTED MACHINE**. Configurations, workshop data, parameters and production data are constantly saved on the new **DigiCLOUD** platform. This service allows you to minimize restart times in the event of hardware and software problems.

The software allows you to:

- Manual insertion of measurements from interface (semi-automatic)
 - Automatic removal of the stop after each cut to facilitate the removal of the piece.
 - Receive the cutting / clamping signal (optional) from the miter saw and display its status on the screen.
 - Radio reception of the measurements from the DigiBAR electronic gauge and creation of the cutting list.
 - Perform positioning cycles while receiving measurements
 - Loading of the cutting list via USB memory.
 - Reception from the Ethernet / Wi-Fi network of the cutting list.
 - Add, delete and edit any row at any time.
 - Skip from one line to another
 - Manage the Head cutting
 - Machine data recovery saving on DigiCLOUD platform
 - Consultation / export of production data / machine status (in compliance with Industry 4.0 protocols) *
- (* Requires activation and subscription)

Electronic	
Control unit (HMI)	Indust PC. 15" Touch Screen SSD Win 10 IoT
Radio Interfaces (DigiBAR commun.)	Integrated
USB for external input device / pen drive	Integrated
WI-FI	integrated
Ethernet	integrated

Intuitive software with use of icons and function keys

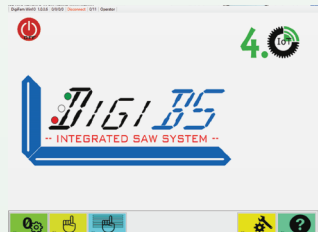

Execution of Cut Lists created with the DigiBAR gauge or received from Network / USB. For each line it is possible to view the order data, bar code, etc.

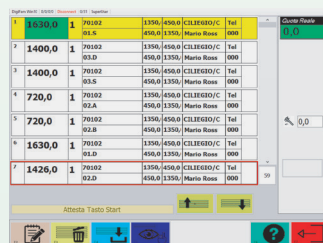

"Manual" execution of pieces

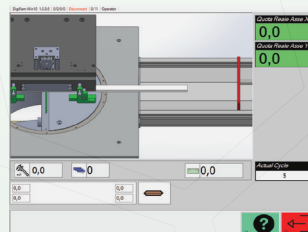

The contextual help integrates the Troubleshooting function

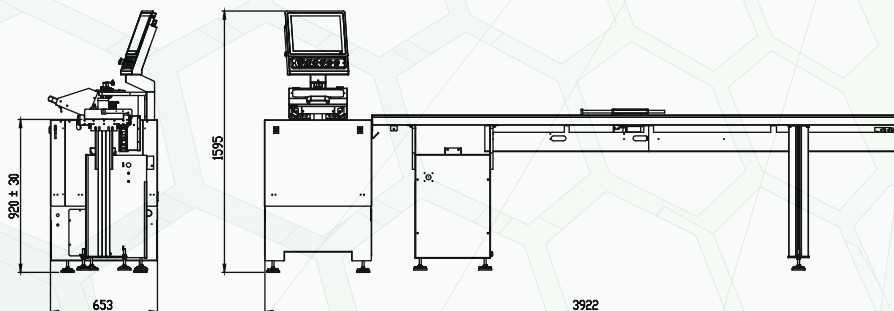
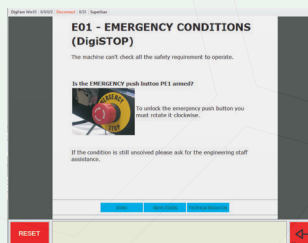

General Features	
Kind of cut	Single Bar Up cut saw
Cutting angles	CNC controlled "arrow cut" from 20 to 160 degrees
Blades	D 300 mm
Blade Motors	Tree-phases 0.75 kW 2800 rpm
Cutting feeding	Pneumatic feed, speed adjustment by external knob
Bars positioning	Exclusive system that allows to cut any type of bead without dedicated counter blocks Pneumatic glass simulator with 12 presets manually selectable or Electronic Glass Simulator for an "infinite" number of profiles
Working plane height	920mm +/-30mm
Minimum and maximum piece measure	180 -3180 mm
Weight	300 Kg
Power Supply	Tree phases 400V 50/60Hz
Carriage movement	Stepper Motor, Magnetic encoder feedback
Accuracy	±0,1 mm
Positioning speed	50 m/min

Professional **M**achines **S**ervice

Via R.Busoni, 22 EMPOLI (FI)
Tel. e Fax 0039 0571 930250
Cell. 0039 340 9478055
info@digistop.it
www.digistop.it